

HGL120-12

Valve Regulated Sealed Lead-Acid Battery

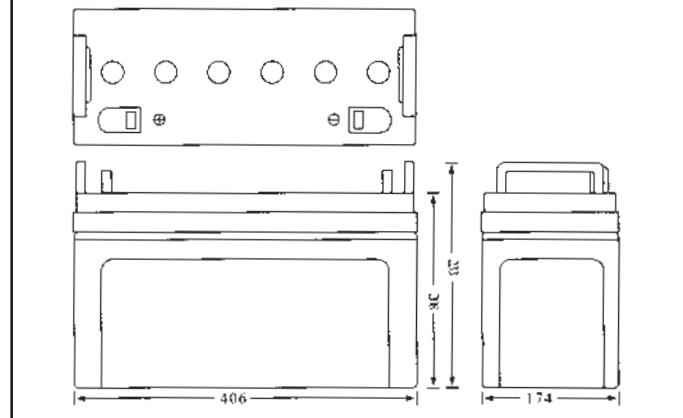

Dimensions (mm)



Specifications

Nominal Voltage		12V
Rated Capacity (20 hours rate)		120Ah
Dimensions (± 2mm)	Total Height (with terminals)	223mm
	Length	406mm
	Width	174mm
	Height	208mm
Approx. Weight		36.5kg
Standard Terminal		A6

Discharge Characteristics

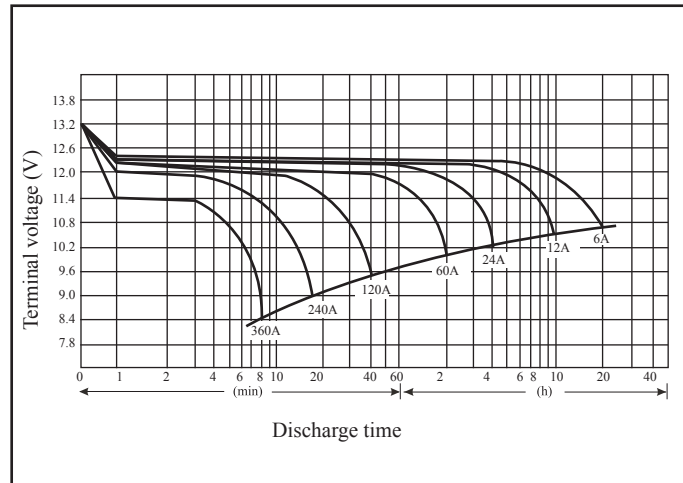

Characteristics

Capacity (25°C)	20 hour rate (5A)	120AH	
	10 hour rate (9.3A)	111.6AH	
	5 hour rate (17A)	102.0AH	
	1 hour rate (57A)	68.4AH	
Internal Resistance	Fully charged Battery 25°C	Approx. 9m	
Capacity affected by temperature (20 hour rate)	40°C	102%	
	25°C	100%	
	0°C	85%	
	-15°C	65%	
Self Discharge (25°C)	Capacity after 3 months storage	92%	
	Capacity after 6 months storage	83%	
	Capacity after 12 months storage	65%	
Charge Method (Constant Voltage)	Cycle use	Initial Current	36A or smaller
		Control Voltage	14.4 to 15.0V (25°C)
	Standby use	Initial Current	36A or smaller
		Control Voltage	13.6 to 13.8V (25°C)

Discharge current & Duration Time

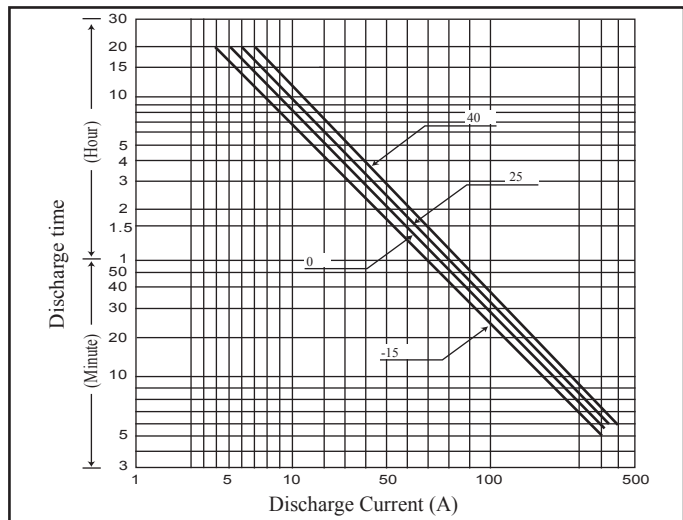

* The above data are average and obtained within three charge/discharge cycles. Cycles not the minimum values.